

Zip HydroTap[®]

Instant Boiling and Chilled Filtered Water
Under-Sink Commercial Models



Under-sink operational unit with filter compartment



Over-sized levers available for people with restricted mobility (optional accessory).



Font installation to accommodate disabled access.



Mounted on sink



Boiling and Chilled model shown with optional Tap Font and 100mm extension.

Features*

Instant boiling filtered water for all commercial tea, coffee and cooking needs

Instant chilled filtered drinking water from the same tap

Unique Power-Pulse™ technology keeps operating costs to a minimum

Two energy-saving power options can be activated to conserve money:

1. A 24/7 programmable clock to turn the system off and on at set times
2. A sleep mode to power system down if inactive for preset periods (2 or 4hrs)

Safety lock mechanism can be activated against boiling water lever

5-micron fully encapsulated filter as standard

Boiling, chilling and filter system stored out-of-sight under the bench top

Optional Tap Font Kit for installation away from the sink and caters for disabled access

Option of over-sized levers for people with restricted mobility

**Energy running costs of around 18 cents* per day if sleep mode activated
Even less using the 24/7 clock to shut the system off during periods of inactivity.**

Description

- Under-sink instant boiling and chilled filtered water from the same tap.
- Unique Power-Pulse™ technology that pulses' only the minimal energy required to maintain optimal performance.
- Two energy efficient, power-saving timer options: sleep mode and 24/7 clock.
- LED indicators for boiling and chilled status and filter change reminder.
- Press lever for controlled dispensing, or lift lever to 'lock on' for filling larger vessels.
- Safety-lock requiring adult finger and thumb operation for boiling water lever.
- Additional safety lock will deactivate boiling water lever.
- Choice of 5 micron or Sub micron filtration to NSF/ANSI 42 and/or 53 industry standards.
- Open outlet, vented system designed to operate between 68°C and 99°C (factory set to 98°C).
- Air cooled (not water cooled) refrigeration system which chills from 5-10°C.
- Plus (+) Models will continue to deliver filtered water after chilled water tank is fully drawn however temperature will be less chilled until full recovery can be achieved.
- Built-in safe tray with leak detector will automatically isolate water supply.

Installation

A. Location

Tap should be installed to dispense into a suitable sink or on the optional Tap Font and if possible, be situated directly above the operational unit, maximum 1 metre away. Font installation may be suitable for placement over drawers and dishwashers and for disability access. Refer installation instructions for detail. Operational unit minimal clearances of 50mm left and right, 220mm above and 65mm rear. Cupboard doors should be offset using 4mm buffers provided.

When installing the unit where minimum clearances are met, consideration should be given to installing an auxiliary exhaust fan accessory (comes standard with BC150/175 and installation is recommended). Suggested exhaust fan location is in side wall to adjoining cupboard or the floor of the cupboard into the kickboard space.

B. Electrical

To be connected in accordance with AS/NZS 3350 wiring regulations to a 10amp GPO, 220V-240VAC power supply with exception of BC240/175+ models which require a 15amp GPO.

C. Plumbing

To be installed by a qualified tradesperson in accordance with manufacturer's instructions and AS/NZS 3500 plumbing regulations. Designed for direct connection to a potable cold water supply with minimum pressure of 70kPa; maximum 700kPa.

If static pressure exceeds 700kPa, a 500kPa pressure limiting valve must be fitted.

An isolating valve should be installed between the water supply and the operational unit.

D. Caution

In some hard water areas where mineral scale accumulation may be a problem, consideration should be given to the maintenance required. A suitable form of water treatment may be necessary.

E. Accessories

- 90046 – Tap Font Kit incl. Shaft
- 90026 – 100mm Extension Shaft only
- 90681 – Aluminium ventilation grill kit
- 90651 – Auxiliary Fan with DIN plug kit
- 91241 – 5 micron replacement filter
- 91240 – Sub micron replacement filter

[†]Refer to Zip HydroTap Brochure for more information
[^]Refer to Zip Energy Consumption Bulletin

Extended Warranty

2 year parts and labour warranty.

Dimensions (see table below)

Note: Image is for illustration purposes only and may not be exactly as depicted. For sink installation, 35mm diameter hole is required. For Font installation, an additional 103mm diameter hole is required-hole template comes with Font accessory kit. Under-sink tubing should be taut for proper drainage.

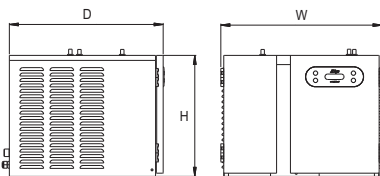

Typical Installation

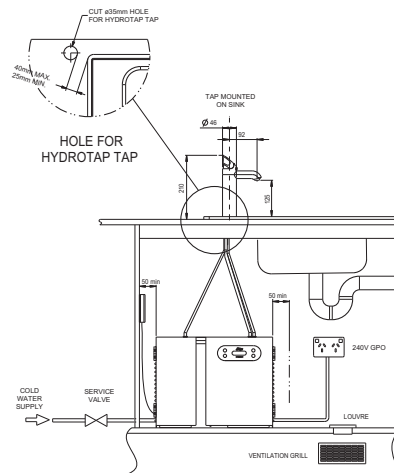

Minimum Clearances (mm)

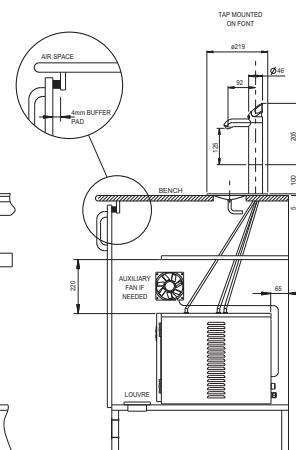

Product Selection Chart

Product Details	Order Code		Order Code Sub		Recovery cups/hr ^	Recovery glasses/hr ^	Tank capacity (boiling)	Tank capacity (chilled)	Total Power Rating*	Dimensions W x D x H (mm)
	Standard	Disabled	Standard	Disabled						
BC(D)240/175+	30291	39296	73198	73199	240	175+	5L	6.5L	3.4kW	500 x 465 x 395
BC(D)150/175	30281	38286	73165	73168	150	175	5L	6.5L	2.1kW	500 x 465 x 395
BC(D)160/125+	39100	39101	39102	39103	160	125+	3L	3.5L	2.3kW	430 x 430 x 337
BC(D)100/125	30271	37276	73164	73167	100	125	3L	3.5L	1.7kW	430 x 430 x 337
BC(D)60/85	37671	37676	73166	73169	60	85	1.5L	3.5L	1.7kW	430 x 430 x 337

Note: BC designates standard levers; BCD for disabled option. ^Standard cup = 167mL, glass = 200ml. *Total power rating includes energy for heating element and compressor for chilling. + Models will continue to deliver filtered water after chilled water tank is fully drawn however temperature will be less chilled until full recovery can be achieved.